

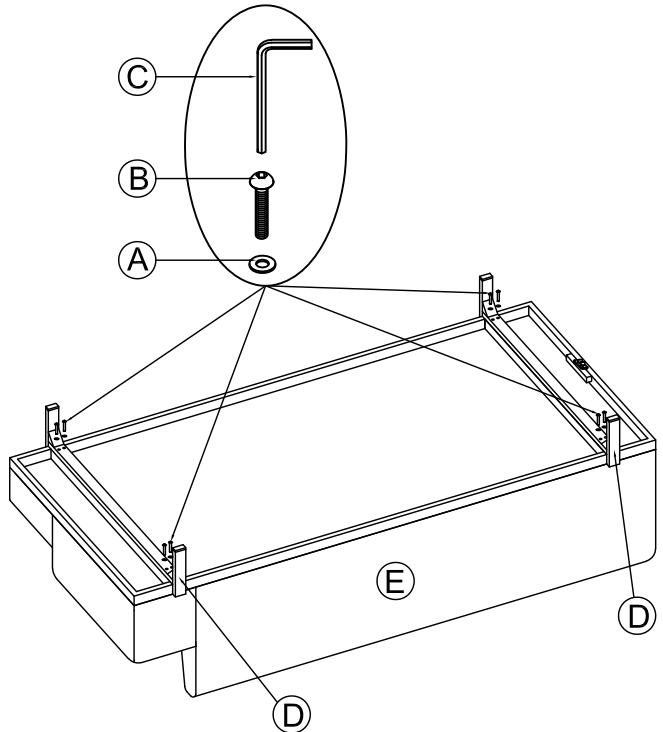

BEFORE ASSEMBLY, PLACE PRODUCT ON A CLEAN, SOFT SURFACE
 BITTE PRODUKT AUF EINEN WEICHEN, SAUBEREN UNTERGRUND LEGEN ZUM MONTIEREN
 PLAATS HET PRODUCT OP EEN ZACHTE, SCHONE ONDERGROND T.B.V.MONTAGE
 POUR ASSEMBLER, POSEZ LE PRODUIT SUR UNE SURFACE DOUCE ET PROPRE
 PARA MONTAJE, PONE EL PRODUCTO A UNA SUPERFICIE SUAVE Y LIMPIA

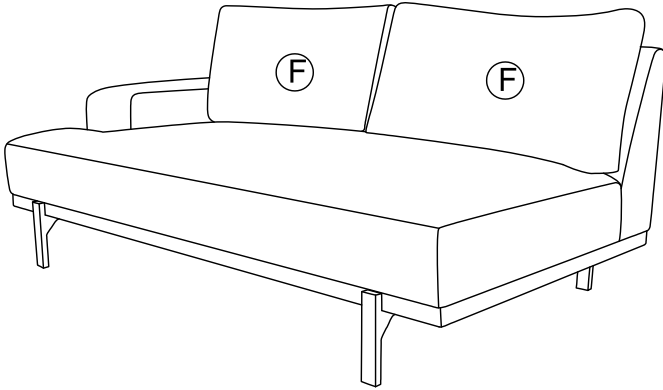
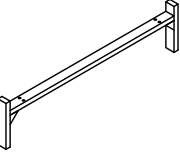
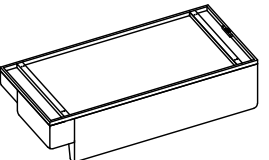
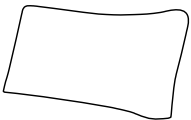

<p>A</p>  <p>M6*Ø16</p> <p>8X</p>	<p>Lucas Corner Lounge Sofa 2-seater</p> <p>PART 1</p> 		<p>PART 2</p> 		
<p>B</p>  <p>M6*40</p> <p>8X</p>					
<p>C</p>  <p>4mm</p> <p>1X</p>			<p>Assemble Instruction:</p> <ol style="list-style-type: none"> Put the seat(E) on plain & Soft surface, align the screw holes on Leg(D) with seat(E). Then fasten them with washer(A) Screw(B)and Allen Key(C). Turn over the aluminum frame 180°and put it on the floor. Installation complete. 		
<p>D</p>  <p>2X</p>	<p>E</p>  <p>1X</p>	<p>F</p>  <p>2X</p>			